

LEDTRONICS-STM-S001-650W-HLV [1500W PHILIPS METAL HALIDE REPLACEMENT



In.Voltage	Order>50
90-277V AC 5Y	\$281.14
480V AC 5Y	\$309.14
90-277V AC 7Y	\$297.76
480V AC 7Y	\$331.76

Remark: certain discount provided based on order qty, sample order add 12%

•POWER: 400W/500W/650W/800W/1000W/1200W

- Heavy-gauge, die-cast aluminum housing with cooling fins.
- Corrosion resistant electrocoat black finish.
- Continuous silicone gasket surrounds lens for weather - tight seal.
- Adjustable angle mounting brackets included.
- High Output SMD LED's with anti UV lens optics.
- High power factor, low THD driver with 6kV/4kA surge protection.
- Optional 20kV/10kA surge protector available.

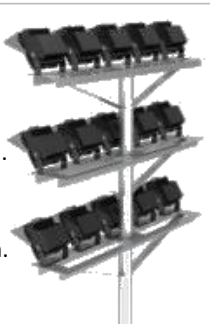

650watt area light (with big yoke)

IP66, 0-10V, **140~160lm/watt**, Black HOUSING ,
Beam angle: 15/30/60/90/140 *70/17/24/36/60
UL ETL driver, 90-277V AC, 347V AC, 480V AC

Low THD driver with 6kV surge protection

Install fitting : big yoke

Optional 20KV/10KA surge protector(option)

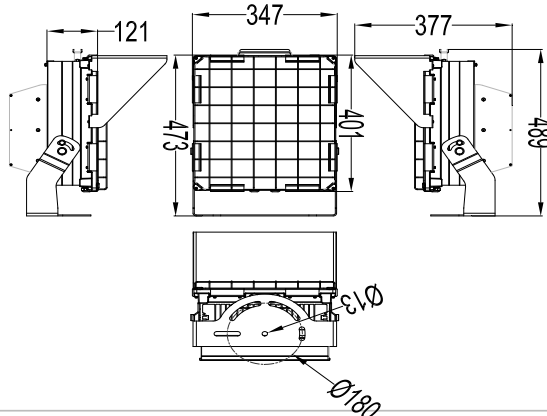

LEDTRONICS-STM-S001-1000W-HLV [2000W PHILIPS METAL HALIDE REPLACEMENT



In.Voltage	Order>50
90-277V AC 5Y	\$449.24
480V AC 5Y	\$505.24
90-277V AC 7Y	\$508.32
480V AC 7Y	\$576.32

Remark: certain discount provided based on order qty, sample order add 12%

•POWER: 400W/500W/650W/800W/1000W/1200W

- Heavy-gauge, die-cast aluminum housing with cooling fins.
- Corrosion resistant electrocoat black finish.
- Continuous silicone gasket surrounds lens for weather - tight seal.
- Adjustable angle mounting brackets included.
- High Output SMD LED's with anti UV lens optics.
- High power factor, low THD driver with 6kV/4kA surge protection.
- Optional 20kV/10kA surge protector available.



1000watt area light (with big yoke)

IP66, 0-10V, **140~160lm/watt**, Black HOUSING ,
Beam angle: 15/30/60/90/140 *70/17/24/36/60
UL ETL driver, 90-277V AC, 347V AC, 480V AC

Low THD driver with 6kV surge protection

Install fitting : big yoke

Optional 20KV/10KA surge protector(option)

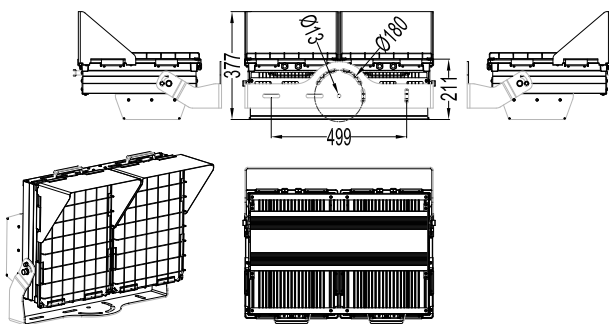

LEDTRONICS-STM-S001-650W-HLV

Shipping port: Shenzhen or Guangzhou
Standard package per item: 1pcs/ctn
Standard package dimensions: 53.5*41*31.5cm/ctn
Standard package weight: 19.2kg/ctn
Estimated weight and volume: 20.1kg/ctn, 0.073cbm/ctn
Estimated Total weight and volume : *
Incoterms of your quote: FOB
Lead time: 25~35days

LEDTRONICS-STM-S001-1000W-HLV

Shipping port: Shenzhen or Guangzhou
Standard package per item: 1pcs/ctn
Standard package dimensions: 76*59*31.5cm/ctn
Standard package weight: 28.2kg/ctn
Estimated weight and volume: 28.7kg/ctn, 0.152cbm/ctn
Estimated Total weight and volume : *
Incoterms of your quote: FOB
Lead time: 25~35days



LEDTRONICS-STM-S002-320W-HLV [1000W PHILIPS METAL HALIDE REPLACEMENT



In.Voltage	Order>50
90-277V AC 5Y	\$133.96
480V AC 5Y	\$161.96
90-277V AC 7Y	\$163.98
480V AC 7Y	\$197.98

Remark: certain discount provided based on order qty, sample order add 12%

POWER: 300W/500W/650W

- Heavy-gauge, die-cast aluminum housing with cooling fins.
- Corrosion resistant electrocoat black finish.
- Continuous silicone gasket surrounds lens for weather - tight seal.
- Adjustable angle mounting brackets included.
- High Output SMD LED's with anti UV lens optics.
- High power factor, low THD driver with 6kV/4kA surge protection.
- Optional 20kV/10kA surge protector available.

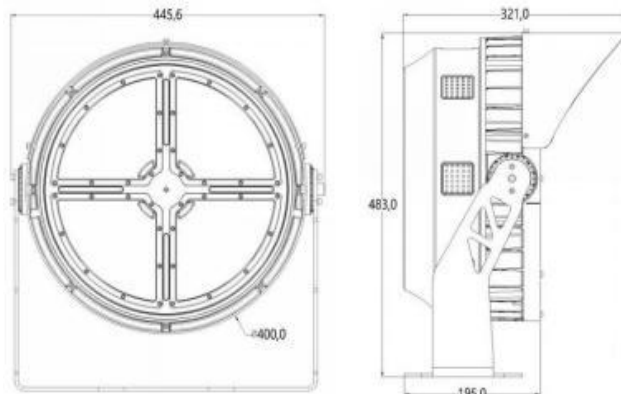

320watt area light (with big yoke)

IP66, 0-10V, **140~160lm/watt**, Black HOUSING ,
 Beam angle: 30° ,60° , 90°
 UL ETL driver, 90-277V AC, 347V AC, 480V AC
Low THD driver with 6kV surge protection
 Install fitting : slipfilter / big yoke
Optional 20KV/10KA surge protector(option)

LEDTRONICS-STM-S002-650W-HLV [1500W PHILIPS METAL HALIDE REPLACEMENT



In.Voltage	Order>50
90-277V AC 5Y	\$241.86
480V AC 5Y	\$297.86
90-277V AC 7Y	\$313.05
480V AC 7Y	\$381.05

Remark: certain discount provided based on order qty, sample order add 12%

POWER: 300W/500W/650W

- Heavy-gauge, die-cast aluminum housing with cooling fins.
- Corrosion resistant electrocoat black finish.
- Continuous silicone gasket surrounds lens for weather - tight seal.
- Adjustable angle mounting brackets included.
- High Output SMD LED's with anti UV lens optics.
- High power factor, low THD driver with 6kV/4kA surge protection.
- Optional 20kV/10kA surge protector available.

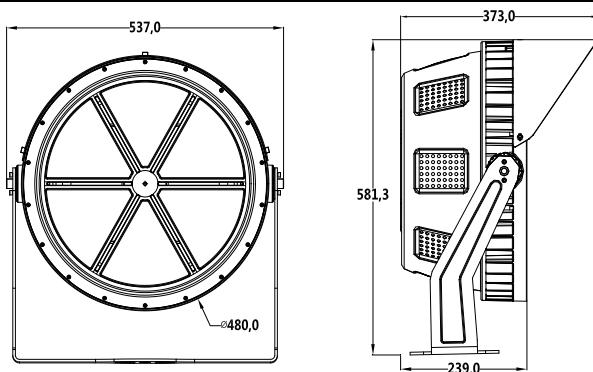

650watt area light (with big yoke / slipfilter)

IP66, 0-10V, **140~160lm/watt**, Black HOUSING ,
 Beam angle: 30° ,60° , 90°
 UL ETL driver, 90-277V AC, 347V AC, 480V AC
Low THD driver with 6kV surge protection
 Install fitting : slipfilter / big yoke
Optional 20KV/10KA surge protector(option)

LEDTRONICS-STM-S002-320W-HLV

Shipping port: Shenzhen or Guangzhou
 Standard package per item: 1pcs/ctn
 Standard package dimensions: 52*51*23cm/ctn
 Standard package weight: 15.1kg/ctn
 Estimated weight and volume: 17.1kg/ctn, 0.073cbm/ctn
 Estimated Total weight and volume : *
 Incoterms of your quote: FOB
 Lead time: 25~35days

LEDTRONICS-STM-S002-650W-HLV

Shipping port: Shenzhen or Guangzhou
 Standard package per item: 1pcs/ctn
 Standard package dimensions: 83*51*23cm/ctn
 Standard package weight: 19.3kg/ctn
 Estimated weight and volume: 21.2kg/ctn, 0.097cbm/ctn
 Estimated Total weight and volume : *
 Incoterms of your quote: FOB
 Lead time: 25~35days



LEDTRONICS-STM-S003-500W-HLV



In.Voltage	Order>50
90-277V AC 5Y	\$219.71
480V AC 5Y	\$247.71
90-277V AC 7Y	\$249.25
480V AC 7Y	\$283.25

Remark: certain discount provided based on order qty, sample order add 12%

POWER: 250W/500W/750W/1000W/1250W/1500W

- Heavy-gauge, die-cast aluminum housing with cooling fins.
- Corrosion resistant electrocoat black finish.
- Continuous silicone gasket surrounds lens for weather - tight seal.
- Adjustable angle mounting brackets included.
- High Output SMD LED's with anti UV lens optics.
- High power factor, low THD driver with 6kV/4kA surge protection.
- Optional 20kV/10kA surge protector available.

500watt area light (with big yoke)

IP66, 0-10V, **140~160lm/watt**, Black HOUSING ,
 Beam angle: 25° ,40° ,50° ,90°
 UL ETL driver, 90-277V AC, 347V AC, 480V AC
Low THD driver with 6kV surge protection
 Install fitting : slipfilter / big yoke
Optional 20KV/10KA surge protector(option)

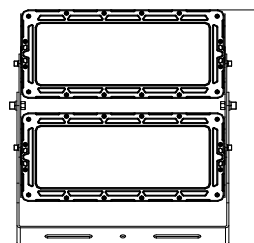
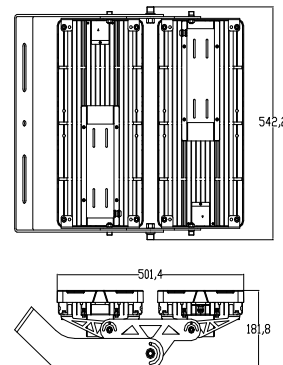

LEDTRONICS-STM-S003-720W-HLV



In.Voltage	Order>50
90-277V AC 5Y	\$315.95
480V AC 5Y	\$371.95
90-277V AC 7Y	\$360.26
480V AC 7Y	\$428.26

Remark: certain discount provided based on order qty, sample order add 12%

POWER: 250W/500W/750W/1000W/1250W/1500W

- Heavy-gauge, die-cast aluminum housing with cooling fins.
- Corrosion resistant electrocoat black finish.
- Continuous silicone gasket surrounds lens for weather - tight seal.
- Adjustable angle mounting brackets included.
- High Output SMD LED's with anti UV lens optics.
- High power factor, low THD driver with 6kV/4kA surge protection.
- Optional 20kV/10kA surge protector available.

720watt area light (with big yoke)

IP66, 0-10V, **140~160lm/watt**, Black HOUSING ,
 Beam angle: 25° ,40° ,50° ,90°
 UL ETL driver, 90-277V AC, 347V AC, 480V AC
Low THD driver with 6kV surge protection
 Install fitting : slipfilter / big yoke
Optional 20KV/10KA surge protector(option)



LEDTRONICS-STM-S003-500W-HLV

Shipping port: Shenzhen or Guangzhou
 Standard package per item: 1pcs/ctn
 Standard package dimensions: 63.5*55*25cm/ctn
 Standard package weight: 19.2kg/ctn
 Estimated weight and volume: 20.1kg/ctn, 0.073cbm/ctn
 Estimated Total weight and volume : *
 Incoterms of your quote: FOB
 Lead time: 25~35days

LEDTRONICS-STM-S003-720W-HLV

Shipping port: Shenzhen or Guangzhou
 Standard package per item: 1pcs/ctn
 Standard package dimensions: 83.5*55*25cm/ctn
 Standard package weight: 28.2kg/ctn
 Estimated weight and volume: 28.7kg/ctn, 0.152cbm/ctn
 Estimated Total weight and volume : *
 Incoterms of your quote: FOB
 Lead time: 25~35days



LEDTRONICS-STM-S004-650W-HLV [1500W PHILIPS METAL HALIDE REPLACEMENT]



In.Voltage	Order>50
110LM/W-7D	\$265.02
120LM/W	\$293.02
140LM/W	\$215.22
160LM/W	\$249.22

7D

650watt area light (with big yoke)

IP66, 0-10V, **140~160lm/watt**, Black HOUSING ,
 Beam angle: 7D/15D/30D/60D/90D/120D/T2M/T3M/T4M
 UL ETL driver, 90-277V AC, 347V AC, 480V AC
Low THD driver with 6kV surge protection
 Install fitting : slipfilter / big yoke
Optional 20KV/10KA surge protector(option)

Remark: certain discount provided based on order qty, sample order add 12%

POWER: 500W/650W/1000W/1250W/1500W/1800W

- Heavy-gauge, die-cast aluminum housing with cooling fins.
- Corrosion resistant electrocoat black finish.
- Continuous silicone gasket surrounds lens for weather - tight seal.
- Adjustable angle mounting brackets included.
- High Output SMD LED's with anti UV lens optics.
- High power factor, low THD driver with 6kV/4kA surge protection.
- Optional 20kV/10kA surge protector available.

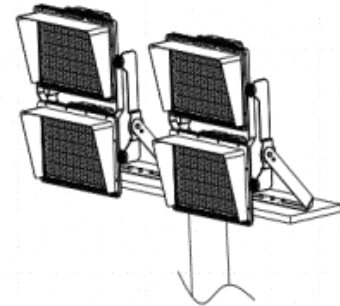
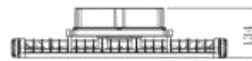
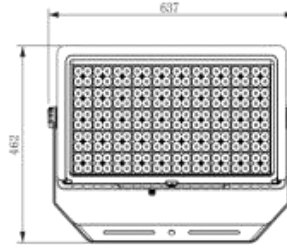

LEDTRONICS-STM-S004-1000W-HLV [2000W PHILIPS METAL HALIDE REPLACEMENT]



In.Voltage	Order>50
110LM/W-7D	\$534.66
120LM/W	\$562.66
140LM/W	\$435.06
160LM/W	\$469.06

7D

1000watt area light (with big yoke)

IP66, 0-10V, **140~160lm/watt**, Black HOUSING ,
 Beam angle: 7D/15D/30D/60D/90D/120D/T2M/T3M/T4M
 UL ETL driver, 90-277V AC, 347V AC, 480V AC
Low THD driver with 6kV surge protection
 Install fitting : slipfilter / big yoke
Optional 20KV/10KA surge protector(option)

Remark: certain discount provided

order add 12%

POWER: 500W/650W/1000W/1250W/1500W/1800W

- Heavy-gauge, die-cast aluminum housing with cooling fins.
- Corrosion resistant electrocoat black finish.
- Continuous silicone gasket surrounds lens for weather - tight seal.
- Adjustable angle mounting brackets included.
- High Output SMD LED's with anti UV lens optics.
- High power factor, low THD driver with 6kV/4kA surge protection.
- Optional 20kV/10kA surge protector available.

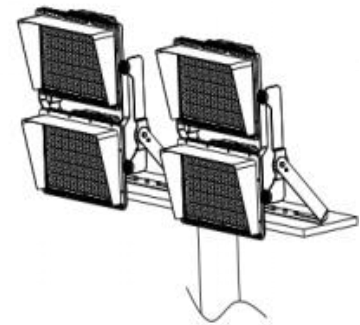
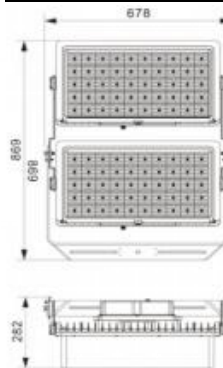

LEDTRONICS-STM-S004-650W-HLV

Shipping port: Shenzhen or Guangzhou
 Standard package per item: 1pcs/ctn
 Standard package dimensions: 56cm*91cm*23cm/ctn
 Standard package weight: 22.7kg/ctn
 Estimated weight and volume: 25.2kg/ctn , 0.1172cbm/ctn
 Estimated Total weight and volume : *
 Incoterms of your quote: FOB
 Lead time: 25~35days

LEDTRONICS-STM-S004-1000W-HLV

Shipping port: Shenzhen or Guangzhou
 Standard package per item: 1pcs/ctn
 Standard package dimensions: 56cm*91cm*23cm/ctn
 Standard package weight: 32.8kg/ctn
 Estimated weight and volume: 35.2kg/ctn , 0.2272cbm/ctn
 Estimated Total weight and volume : *
 Incoterms of your quote: FOB
 Lead time: 25~35days



LEDTRONICS-STM-S005-650W-HLV [1500W PHILIPS METAL HALIDE REPLACEMENT



In.Voltage	Order>50
90-277V AC 5Y	\$269.58
480V AC 5Y	\$297.58
90-277V AC 7Y	\$286.20
480V AC 7Y	\$320.20

Remark: certain discount provided based on order qty, sample order add 12%

•POWER: 500W/650W/850W/1000W/1250W

- Heavy-gauge, die-cast aluminum housing with cooling fins.
- Corrosion resistant electrocoat black finish.
- Continuous silicone gasket surrounds lens for weather - tight seal.
- Adjustable angle mounting brackets included.
- High Output SMD LED's with anti UV lens optics.
- High power factor, low THD driver with 6kV/4kA surge protection.
- Optional 20kV/10kA surge protector available.



650watt area light (with big yoke / slipfilter/holder)

IP66, 0-10V, **140~160lm/watt**, Black HOUSING ,
 Beam angle: 10° ,25° ,45° , 60°
 UL ETL driver, 90-277V AC, 347V AC, 480V AC
Low THD driver with 6kV surge protection
 Install fitting : slipfilter / big yoke
Optional 20KV/10KA surge protector(option)

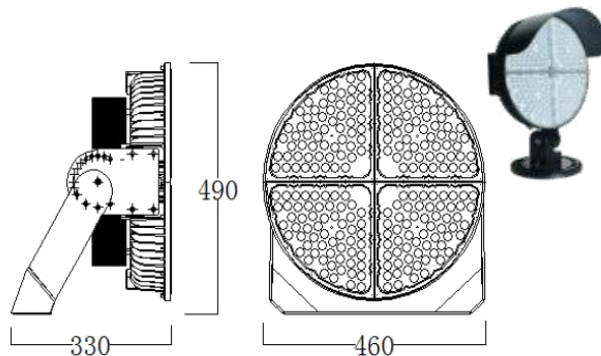

LEDTRONICS-STM-S005-1000W-HLV [2000W PHILIPS METAL HALIDE REPLACEMENT



In.Voltage	Order>50
90-277V AC 5Y	\$440.77
480V AC 5Y	\$496.77
90-277V AC 7Y	\$499.85
480V AC 7Y	\$567.85

Remark: certain discount provided based on order qty, sample order add 12%

•POWER: 500W/650W/850W/1000W/1250W

- Heavy-gauge, die-cast aluminum housing with cooling fins.
- Corrosion resistant electrocoat black finish.
- Continuous silicone gasket surrounds lens for weather - tight seal.
- Adjustable angle mounting brackets included.
- High Output SMD LED's with anti UV lens optics.
- High power factor, low THD driver with 6kV/4kA surge protection.
- Optional 20kV/10kA surge protector available.



1000watt area light (with big yoke /slipfilter/holder)

IP66, 0-10V, **140~160lm/watt**, Black HOUSING ,
 Beam angle: 10° ,25° ,45° , 60°
 UL ETL driver, 90-277V AC, 347V AC, 480V AC
Low THD driver with 6kV surge protection
 Install fitting : slipfilter / big yoke
Optional 20KV/10KA surge protector(option)

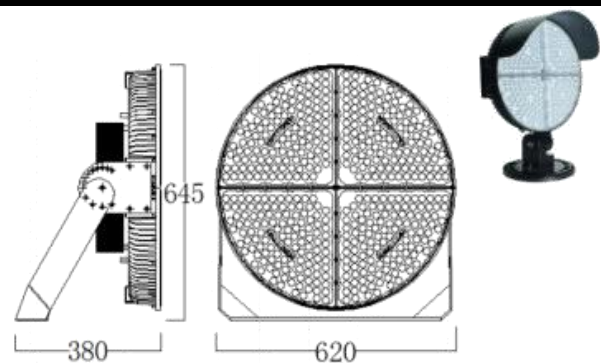

LEDTRONICS-STM-S005-650W-HLV

Shipping port: Shenzhen or Guangzhou
 Standard package per item: 1pcs/ctn
 Standard package dimensions: 62*51*23cm/ctn
 Standard package weight: 19.2kg/ctn
 Estimated weight and volume: 20.1kg/ctn, 0.073cbm/ctn
 Estimated Total weight and volume : *
 Incoterms of your quote: FOB
 Lead time: 25~35days

LEDTRONICS-STM-S005-1000W-HLV

Shipping port: Shenzhen or Guangzhou
 Standard package per item: 1pcs/ctn
 Standard package dimensions: 86*68*26cm/ctn
 Standard package weight: 28.2kg/ctn
 Estimated weight and volume: 28.7kg/ctn, 0.152cbm/ctn
 Estimated Total weight and volume : *
 Incoterms of your quote: FOB
 Lead time: 25~35days



LEDTRONICS-STM-S006-720W-HLV [2000W PHILIPS METAL HALIDE REPLACEMENT

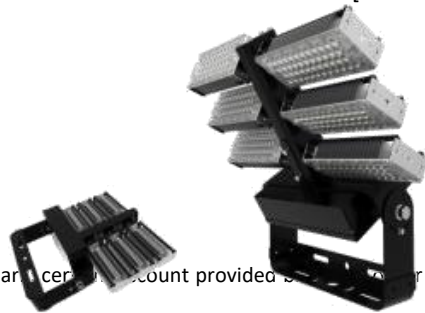

In.Voltage	Order>50
90-277V AC 5Y	\$415.83
480V AC 5Y	\$443.83
90-277V AC 7Y	\$469.31
480V AC 7Y	\$503.31

Remark: unit price is based on quantity provided, sample order add 12%

POWER: 720W/960W/1200W/1500W

- Heavy-gauge, die-cast aluminum housing with cooling fins.
- Corrosion resistant electrocoat black finish.
- Continuous silicone gasket surrounds lens for weather - tight seal.
- Adjustable angle mounting brackets included.
- High Output SMD LED's with anti UV lens optics.
- High power factor, low THD driver with 6kV/4kA surge protection.
- Optional 20kV/10kA surge protector available.

720watt area light (with big yoke)

IP66, 0-10V, **140~160lm/watt**, Black HOUSING ,
 Beam angle: 20D/40D/60D/90D/140x100D
 UL ETL driver, 90-277V AC, 347V AC, 480V AC
Low THD driver with 6kV surge protection
 Install fitting : slipfilter / big yoke
Optional 20KV/10KA surge protector(option)

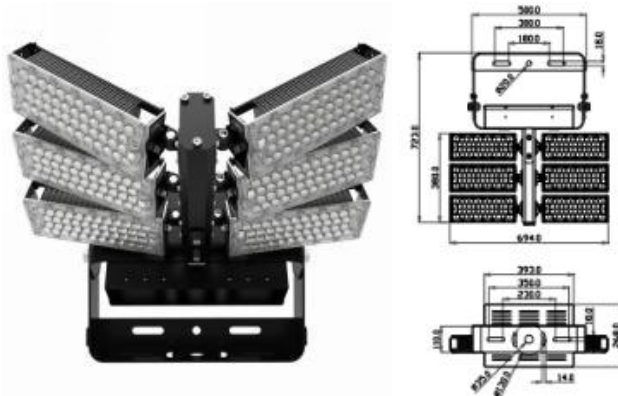

LEDTRONICS-STM-S006-960W-HLV [2000W PHILIPS METAL HALIDE REPLACEMENT

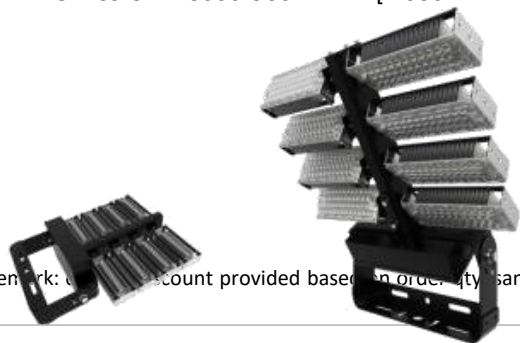

In.Voltage	Order>50
90-277V AC 5Y	\$476.48
480V AC 5Y	\$532.48
90-277V AC 7Y	\$533.02
480V AC 7Y	\$601.02

Remark: unit price is based on quantity provided, sample order add 12%

POWER: 720W/960W/1200W/1500W

- Heavy-gauge, die-cast aluminum housing with cooling fins.
- Corrosion resistant electrocoat black finish.
- Continuous silicone gasket surrounds lens for weather - tight seal.
- Adjustable angle mounting brackets included.
- High Output SMD LED's with anti UV lens optics.
- High power factor, low THD driver with 6kV/4kA surge protection.
- Optional 20kV/10kA surge protector available.

960watt area light (with big yoke)

IP66, 0-10V, **140~160lm/watt**, Black HOUSING ,
 Beam angle: 20D/40D/60D/90D/140x100D
 UL ETL driver, 90-277V AC, 347V AC, 480V AC
Low THD driver with 6kV surge protection
 Install fitting : slipfilter / big yoke
Optional 20KV/10KA surge protector(option)

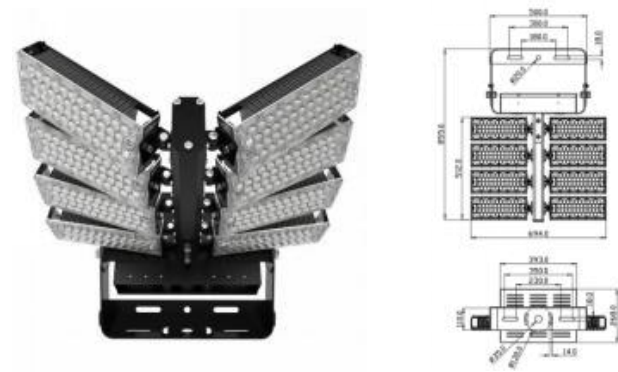

LEDTRONICS-STM-S006-720W-HLV

Shipping port: Shenzhen or Guangzhou
 Standard package per item: 1pcs/ctn
 Standard package dimensions: 87*51*68cm/ctn
 Standard package weight: 23.1kg/ctn
 Estimated weight and volume: 23.1kg/ctn, 0.073cbm/ctn
 Estimated Total weight and volume : *
 Incoterms of your quote: FOB
 Lead time: 25~35days

LEDTRONICS-STM-S006-960W-HLV

Shipping port: Shenzhen or Guangzhou
 Standard package per item: 1pcs/ctn
 Standard package dimensions: 87*51*78cm/ctn
 Standard package weight: 29.3kg/ctn
 Estimated weight and volume: 31.2kg/ctn, 0.097cbm/ctn
 Estimated Total weight and volume : *
 Incoterms of your quote: FOB
 Lead time: 25~35days



LEDTRONICS-STM-S007-650W-HLV [1500W PHILIPS METAL HALIDE REPLACEMENT

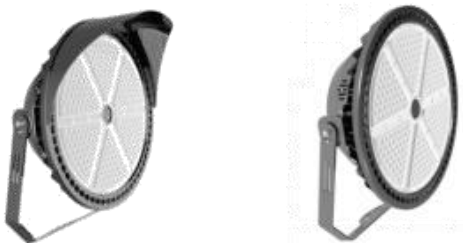

In.Voltage	Order>50
90-277V AC 5Y	\$253.59
480V AC 5Y	\$281.59
90-277V AC 7Y	\$270.20
480V AC 7Y	\$304.20

Remark: certain discount provided based on order qty, sample order add 12%

650watt area light (with big yoke / slipfilter)

IP66, 0-10V, **140~160lm/watt**, Black HOUSING ,
 Beam angle: 15° , 30° , 60°
 UL ETL driver, 90-277V AC, 347V AC, 480V AC
Low THD driver with 6kV surge protection
 Install fitting : slipfilter / big yoke
Optional 20KV/10KA surge protector(option)

•POWER: 300W/500W/650W/850W/1000W/1250W

- Heavy-gauge, die-cast aluminum housing with cooling fins.
- Corrosion resistant electrocoat black finish.
- Continuous silicone gasket surrounds lens for weather - tight seal.
- Adjustable angle mounting brackets included.
- High Output SMD LED's with anti UV lens optics.
- High power factor, low THD driver with 6kV/4kA surge protection.
- Optional 20kV/10kA surge protector available.

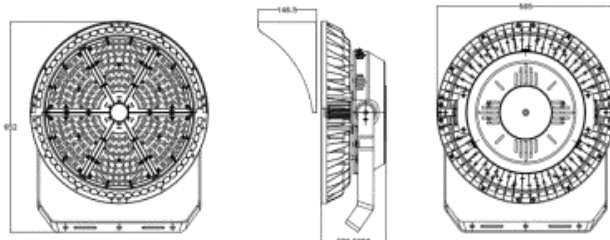

LEDTRONICS-STM-S007-850W-HLV [2000W PHILIPS METAL HALIDE REPLACEMENT

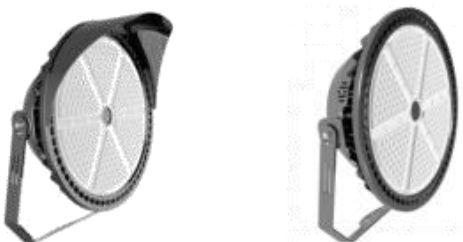

In.Voltage	Order>50
90-277V AC 5Y	\$371.42
480V AC 5Y	\$427.42
90-277V AC 7Y	\$415.73
480V AC 7Y	\$483.73

Remark: certain discount provided based on order qty, sample order add 12%

850watt area light (with big yoke / slipfilter)

IP66, 0-10V, **140~160lm/watt**, Black HOUSING ,
 Beam angle: 15° ,30°
 UL ETL driver, 90-277V AC, 347V AC, 480V AC
Low THD driver with 6kV surge protection
 Install fitting : slipfilter / big yoke
Optional 20KV/10KA surge protector(option)

•POWER: 300W/500W/650W/850W/1000W/1250W

- Heavy-gauge, die-cast aluminum housing with cooling fins.
- Corrosion resistant electrocoat black finish.
- Continuous silicone gasket surrounds lens for weather - tight seal.
- Adjustable angle mounting brackets included.
- High Output SMD LED's with anti UV lens optics.
- High power factor, low THD driver with 6kV/4kA surge protection.
- Optional 20kV/10kA surge protector available.

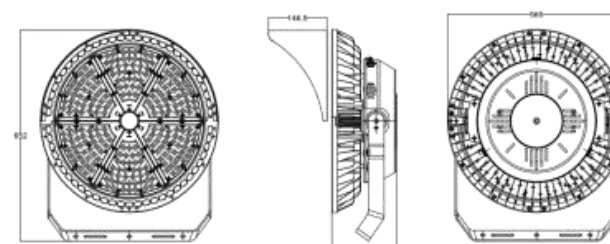

LEDTRONICS-STM-S007-650W-HLV

Shipping port: Shenzhen or Guangzhou
 Standard package per item: 1pcs/ctn
 Standard package dimensions: 68cm*58cm*37cm/ctn
 Standard package weight: 17.3kg/ctn
 Estimated weight and volume: 19.2kg/ctn , 0.2087cbm/ctn
 Estimated Total weight and volume : *
 Incoterms of your quote: FOB
 Lead time: 25~35days

LEDTRONICS-STM-S007-850W-HLV

Shipping port: Shenzhen or Guangzhou
 Standard package per item: 1pcs/ctn
 Standard package dimensions: 68cm*58cm*41cm/ctn
 Standard package weight: 18.6kg/ctn
 Estimated weight and volume: 20.7kg/ctn , 0.2087cbm/ctn
 Estimated Total weight and volume : *
 Incoterms of your quote: FOB
 Lead time: 25~35days



LEDTRONICS-STM-S008-xxxW-ECO [25°, 60°, 90°]



WATTAGE	LPW	CRI	LIFESPAN	WARRANTY	PRICE
240W	>140	70/80/90	50K hours	5 year	\$86.78
320W	>140	70/80/90	50K hours	5 year	\$115.61
480W	>140	70/80/90	50K hours	5 year	\$154.78
600W	>140	70/80/90	50K hours	5 year	\$209.65
720W	>140	70/80/90	50K hours	5 year	\$231.16
800W	>140	70/80/90	50K hours	5 year	\$306.51

LEDTRONICS-STM-S008-xxxW-HQ [25°, 60°, 90°]



WATTAGE	LPW	CRI	LIFESPAN	WARRANTY	PRICE
240W	>160	70/80/90	70K hours	7 year	\$102.07
320W	>160	70/80/90	70K hours	7 year	\$196.08
480W	>160	70/80/90	70K hours	7 year	\$288.08
600W	>160	70/80/90	70K hours	7 year	\$361.75
720W	>160	70/80/90	70K hours	7 year	\$431.11
800W	>160	70/80/90	70K hours	7 year	\$512.53

Remark: certain discount provided based on actual order quantity, sample price add 8%

Install fixture: big yoke, U-bracket

240W//320W

480W/600W

720W/800W

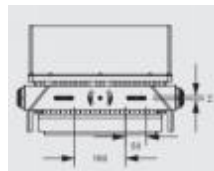
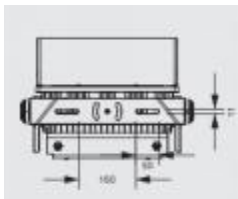
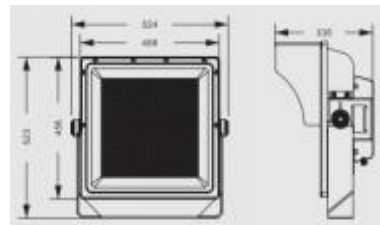
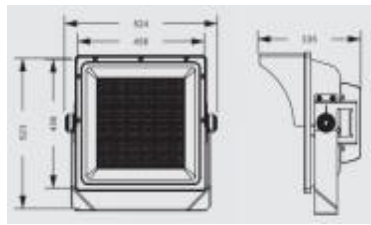
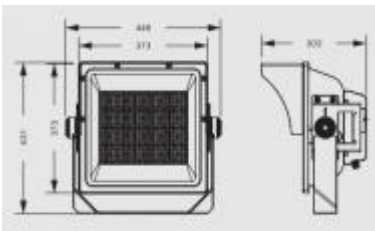

LEDTRONICS-STM-S009-650W-HLV [1500W PHILIPS METAL HALIDE REPLACEMENT

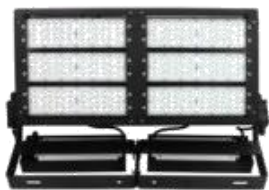

In.Voltage	Order>50
90-277V AC 5Y	\$318.17
480V AC 5Y	\$346.17
90-277V AC 7Y	\$334.78
480V AC 7Y	\$368.78

Remark: certain discount provided based on order volume, sample order add 12%

•POWER: 300W/400W/500W/650W/850W/960W/1000W

- Heavy-gauge, die-cast aluminum housing with cooling fins.
- Corrosion resistant electrocoat black finish.
- Continuous silicone gasket surrounds lens for weather - tight seal.
- Adjustable angle mounting brackets included.
- High Output SMD LED's with anti UV lens optics.
- High power factor, low THD driver with 6kV/4kA surge protection.
- Optional 20kV/10kA surge protector available.

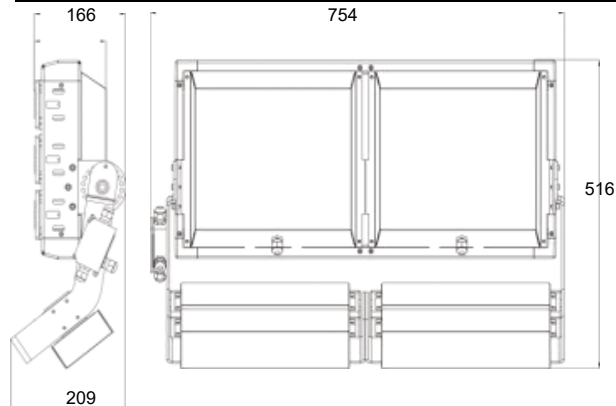

850watt area light (with big yoke / slipfilter)

IP66, 0-10V, **140~160lm/watt**, Black HOUSING ,
 Beam angle: 25° ,45° ,60° ,55*140°
 UL ETL driver, 90-277V AC, 347V AC, 480V AC
Low THD driver with 6kV surge protection
 Install fitting : slipfilter / big yoke
Optional 20KV/10KA surge protector(option)

LEDTRONICS-STM-S009-850W-HLV [2000W PHILIPS METAL HALIDE REPLACEMENT



In.Voltage	Order>50
90-277V AC 5Y	\$390.85
480V AC 5Y	\$446.85
90-277V AC 7Y	\$435.16
480V AC 7Y	\$503.16

Remark: certain discount provided based on order volume, sample order add 12%

•POWER: 300W/400W/500W/650W/850W/960W/1000W

- Heavy-gauge, die-cast aluminum housing with cooling fins.
- Corrosion resistant electrocoat black finish.
- Continuous silicone gasket surrounds lens for weather - tight seal.
- Adjustable angle mounting brackets included.
- High Output SMD LED's with anti UV lens optics.
- High power factor, low THD driver with 6kV/4kA surge protection.
- Optional 20kV/10kA surge protector available.

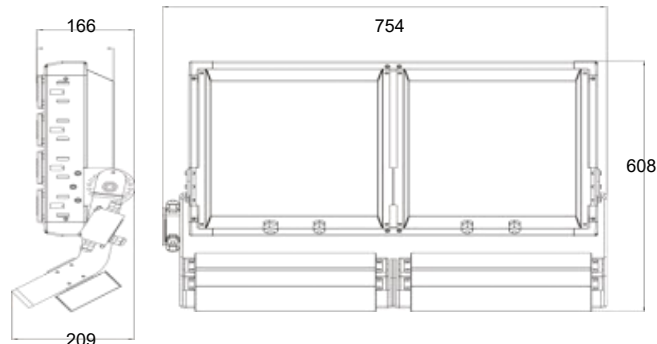

LEDTRONICS-STM-S009-650W-HLV

Shipping port: Shenzhen or Guangzhou
 Standard package per item: 1pcs/ctn
 Standard package dimensions: 78cm*26cm*56cm/ctn
 Standard package weight: 20.6kg/ctn
 Estimated weight and volume: 23.7kg/ctn , 0.1136cbm/ctn
 Estimated Total weight and volume : *
 Incoterms of your quote: FOB
 Lead time: 25~35days

LEDTRONICS-STM-S009-850W-HLV

Shipping port: Shenzhen or Guangzhou
 Standard package per item: 1pcs/ctn
 Standard package dimensions: 78cm*26cm*65cm/ctn
 Standard package weight: 25.2kg/ctn
 Estimated weight and volume: 28.6kg/ctn , 0.132cbm/ctn
 Estimated Total weight and volume : *
 Incoterms of your quote: FOB
 Lead time: 25~35days



LEDTRONICS-STM-S010-xxxW-ECO [15°, 30°, 45°, 60°, 120°]



WATTAGE	LPW	CRI	LIFESPAN	WARRANTY	PRICE
150W	>140	70/80/90	50K hours	5 year	\$66.80
200W	>140	70/80/90	50K hours	5 year	\$74.16
240W	>140	70/80/90	50K hours	5 year	\$80.82
400W	>140	70/80/90	50K hours	5 year	\$148.31
540W	>140	70/80/90	50K hours	5 year	\$212.48
600W	>140	70/80/90	50K hours	5 year	\$234.10

LEDTRONICS-STM-S010-xxxW-HQ [15°, 30°, 45°, 60°, 120°]



WATTAGE	LPW	CRI	LIFESPAN	WARRANTY	PRICE
150W	>160	70/80/90	70K hours	7 year	\$81.44
200W	>160	70/80/90	70K hours	7 year	\$132.93
240W	>160	70/80/90	70K hours	7 year	\$151.35
400W	>160	70/80/90	70K hours	7 year	\$265.86
540W	>160	70/80/90	70K hours	7 year	\$366.81
600W	>160	70/80/90	70K hours	7 year	\$398.79

Remark: certain discount provided based on actual order quantity, sample price add 8%

Install fixture: big yoke, U-bracket

240W

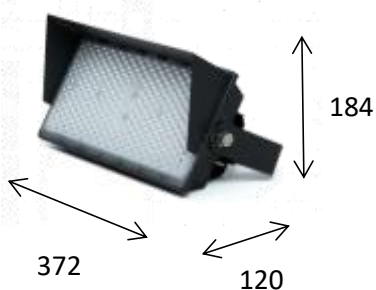

400W

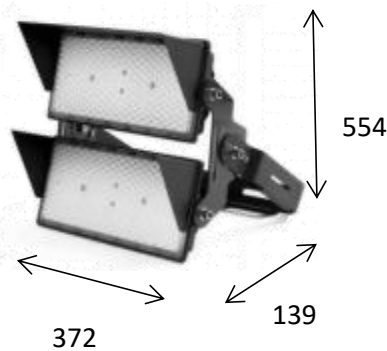

600W

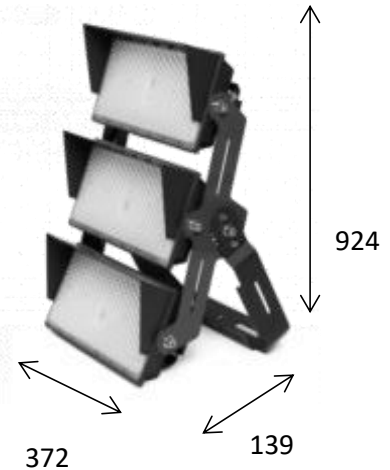

LEDTRONICS-STM-S011-650W-HLV [1500W PHILIPS METAL HALIDE REPLACEMENT



In.Voltage	Order>50
90-277V AC 5Y	\$233.78
480V AC 5Y	\$261.78
90-277V AC 7Y	\$250.39
480V AC 7Y	\$284.39

Remark: certain discount provided based on order qty, sample order add 12%

POWER: 500W/650W/750W/1000W/1250W

- Heavy-gauge, die-cast aluminum housing with cooling fins.
- Corrosion resistant electrocoat black finish.
- Continuous silicone gasket surrounds lens for weather - tight seal.
- Adjustable angle mounting brackets included.
- High Output SMD LED's with anti UV lens optics.
- High power factor, low THD driver with 6kV/4kA surge protection.
- Optional 20kV/10kA surge protector available.

650watt area light (with big yoke / slipfilter)

IP66, 0-10V, **140~160lm/watt**, Black HOUSING ,
 Beam angle: 10° ,25° ,45° , 60°
 UL ETL driver, 90-277V AC, 347V AC, 480V AC
Low THD driver with 6kV surge protection
 Install fitting : slipfilter / big yoke
Optional 20KV/10KA surge protector(option)

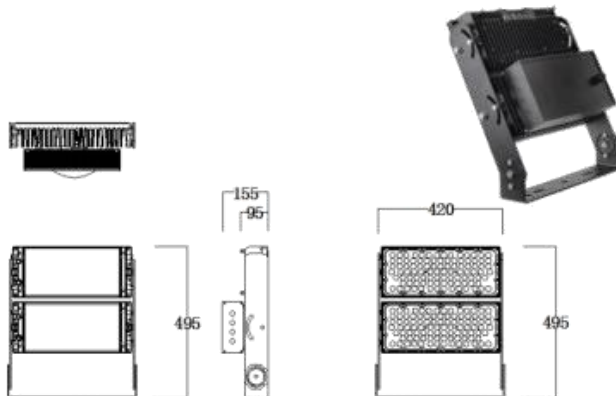

LEDTRONICS-STM-S011-750W-HLV [2000W PHILIPS METAL HALIDE REPLACEMENT



In.Voltage	Order>50
90-277V AC 5Y	\$298.33
480V AC 5Y	\$354.33
90-277V AC 7Y	\$342.64
480V AC 7Y	\$410.64

Remark: certain discount provided based on order qty, sample order add 12%

POWER: 500W/650W/750W/1000W/1250W

- Heavy-gauge, die-cast aluminum housing with cooling fins.
- Corrosion resistant electrocoat black finish.
- Continuous silicone gasket surrounds lens for weather - tight seal.
- Adjustable angle mounting brackets included.
- High Output SMD LED's with anti UV lens optics.
- High power factor, low THD driver with 6kV/4kA surge protection.
- Optional 20kV/10kA surge protector available.

750watt area light (with big yoke / slipfilter)

IP66, 0-10V, **140~160lm/watt**, Black HOUSING ,
 Beam angle: 10° ,25° ,45° , 60°
 UL ETL driver, 90-277V AC, 347V AC, 480V AC
Low THD driver with 6kV surge protection
 Install fitting : slipfilter / big yoke
Optional 20KV/10KA surge protector(option)

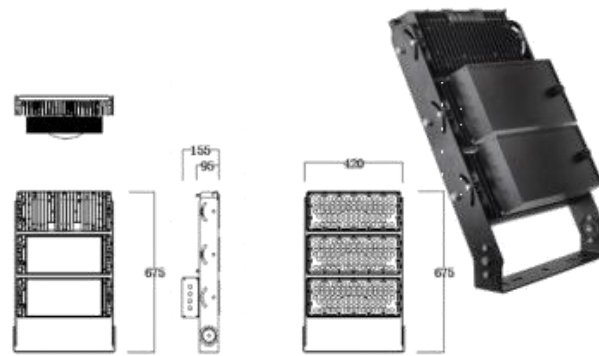

LEDTRONICS-STM-S011-650W-HLV

Shipping port: Shenzhen or Guangzhou
 Standard package per item: 1pcs/ctn
 Standard package dimensions: 62*51*23cm/ctn
 Standard package weight: 15.1kg/ctn
 Estimated weight and volume: 17.1kg/ctn, 0.073cbm/ctn
 Estimated Total weight and volume : *
 Incoterms of your quote: FOB
 Lead time: 25~35days

LEDTRONICS-STM-S011-750W-HLV

Shipping port: Shenzhen or Guangzhou
 Standard package per item: 1pcs/ctn
 Standard package dimensions: 83*51*23cm/ctn
 Standard package weight: 19.3kg/ctn
 Estimated weight and volume: 21.2kg/ctn, 0.097cbm/ctn
 Estimated Total weight and volume : *
 Incoterms of your quote: FOB
 Lead time: 25~35days



LEDTRONICS-STM-S012-720W-HLV [2000W PHILIPS METAL HALIDE REPLACEMENT



In.Voltage	Order>50
90-277V AC 5Y	\$284.33
480V AC 5Y	\$312.33
90-277V AC 7Y	\$314.79
480V AC 7Y	\$348.79

Remark: certain discount provided based on order qty, sample order add 12%

•POWER: 250W/500W/720W/1000W/1250W

- Heavy-gauge, die-cast aluminum housing with cooling fins.
 - Corrosion resistant electrocoat black finish.
 - Continuous silicone gasket surrounds lens for weather - tight seal.
 - Adjustable angle mounting brackets included.
 - High Output SMD LED's with anti UV lens optics.
 - High power factor, low THD driver with 6kV/4kA surge protection.
- Optional 20kV/10kA surge protector available.



720watt area light (with big yoke)

IP66, 0-10V, **140~160lm/watt**, Black HOUSING ,
 Beam angle: 10D/20D/40D/60DX50D
 UL ETL driver, 90-277V AC, 347V AC, 480V AC
Low THD driver with 6kV surge protection
 Install fitting : slipfilter / big yoke
Optional 20KV/10KA surge protector(option)

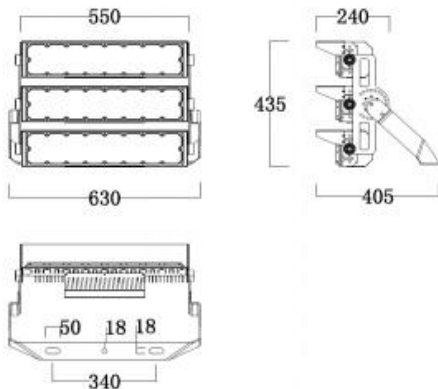

LEDTRONICS-STM-S012-960W-HLV [2000W PHILIPS METAL HALIDE REPLACEMENT



In.Voltage	Order>50
90-277V AC 5Y	\$375.52
480V AC 5Y	\$431.52
90-277V AC 7Y	\$416.13
480V AC 7Y	\$484.13

Remark: certain discount provided based on order qty, sample order add 12%

•POWER: 250W/500W/720W/1000W/1250W

- Heavy-gauge, die-cast aluminum housing with cooling fins.
 - Corrosion resistant electrocoat black finish.
 - Continuous silicone gasket surrounds lens for weather - tight seal.
 - Adjustable angle mounting brackets included.
 - High Output SMD LED's with anti UV lens optics.
 - High power factor, low THD driver with 6kV/4kA surge protection.
- Optional 20kV/10kA surge protector available.



960watt area light (with big yoke)

IP66, 0-10V, **140~160lm/watt**, Black HOUSING ,
 Beam angle: 10D/20D/40D/60DX50D
 UL ETL driver, 90-277V AC, 347V AC, 480V AC
Low THD driver with 6kV surge protection
 Install fitting : slipfilter / big yoke
Optional 20KV/10KA surge protector(option)

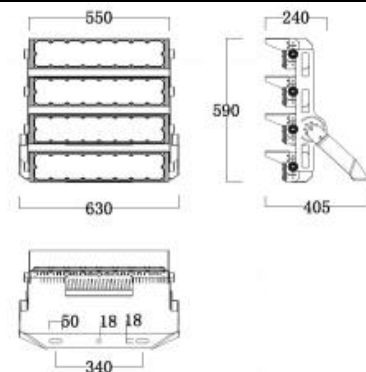

LEDTRONICS-STM-S012-720W-HLV

Shipping port: Shenzhen or Guangzhou
 Standard package per item: 1pcs/ctn
 Standard package dimensions: 87*51*68cm/ctn
 Standard package weight: 23.1kg/ctn
 Estimated weight and volume:23.1kg/ctn, 0.073cbm/ctn
 Estimated Total weight and volume : *
 Incoterms of your quote: FOB
 Lead time: 25~35days

LEDTRONICS-STM-S012-960W-HLV

Shipping port: Shenzhen or Guangzhou
 Standard package per item: 1pcs/ctn
 Standard package dimensions: 87*51*78cm/ctn
 Standard package weight: 29.3kg/ctn
 Estimated weight and volume: 31.2kg/ctn, 0.097cbm/ctn
 Estimated Total weight and volume : *
 Incoterms of your quote: FOB
 Lead time: 25~35days



LEDTRONICS-STM-S013-500W-HLV [1500W PHILIPS METAL HALIDE REPLACEMENT

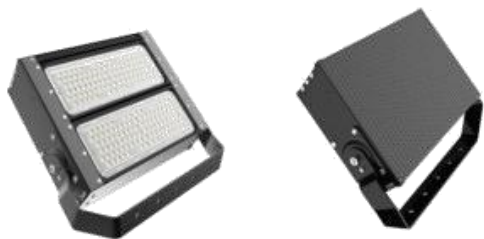

In.Voltage	Order>50
90-277V AC 5Y	\$202.45
480V AC 5Y	\$230.45
90-277V AC 7Y	\$231.99
480V AC 7Y	\$265.99

Remark: certain discount provided based on order qty, sample order add 12%

500watt area light (with big yoke)

IP66, 0-10V, **140~160lm/watt**, Black HOUSING ,
 Beam angle: 15° ,30°
 UL ETL driver, 90-277V AC, 347V AC, 480V AC
Low THD driver with 6kV surge protection
 Install fitting : slipfilter / big yoke
Optional 20KV/10KA surge protector(option)

·POWER: 250W/500W/750W/1000W/1250W/1500W

- Heavy-gauge, die-cast aluminum housing with cooling fins.
- Corrosion resistant electrocoat black finish.
- Continuous silicone gasket surrounds lens for weather - tight seal.
- Adjustable angle mounting brackets included.
- High Output SMD LED's with anti UV lens optics.
- High power factor, low THD driver with 6kV/4kA surge protection.
- Optional 20kV/10kA surge protector available.

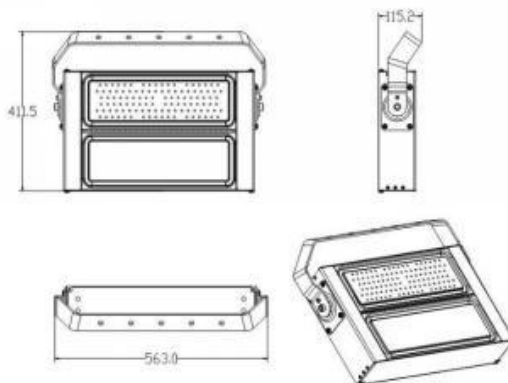

LEDTRONICS-STM-S013-1000W-HLV [2000W PHILIPS METAL HALIDE REPLACEMENT



In.Voltage	Order>50
90-277V AC 5Y	\$368.25
480V AC 5Y	\$424.25
90-277V AC 7Y	\$427.33
480V AC 7Y	\$495.33

Remark: certain discount provided based on order qty, sample order add 12%

1000watt area light (with big yoke / slipfilter)

IP66, 0-10V, **140~160lm/watt**, Black HOUSING ,
 Beam angle: 15° ,30°
 UL ETL driver, 90-277V AC, 347V AC, 480V AC
Low THD driver with 6kV surge protection
 Install fitting : slipfilter / big yoke
Optional 20KV/10KA surge protector(option)

·POWER: 250W/500W/750W/1000W/1250W/1500W

- Heavy-gauge, die-cast aluminum housing with cooling fins.
- Corrosion resistant electrocoat black finish.
- Continuous silicone gasket surrounds lens for weather - tight seal.
- Adjustable angle mounting brackets included.
- High Output SMD LED's with anti UV lens optics.
- High power factor, low THD driver with 6kV/4kA surge protection.
- Optional 20kV/10kA surge protector available.

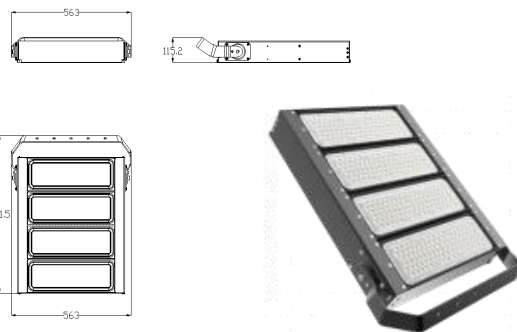

LEDTRONICS-STM-S013-500W-HLV

Shipping port: Shenzhen or Guangzhou
 Standard package per item: 1pcs/ctn
 Standard package dimensions: 52*51*23cm/ctn
 Standard package weight: 15.1kg/ctn
 Estimated weight and volume:17.1kg/ctn, 0.073cbm/ctn
 Estimated Total weight and volume : *
 Incoterms of your quote: FOB
 Lead time: 25~35days

LEDTRONICS-STM-S013-1000W-HLV

Shipping port: Shenzhen or Guangzhou
 Standard package per item: 1pcs/ctn
 Standard package dimensions: 83*51*23cm/ctn
 Standard package weight: 19.3kg/ctn
 Estimated weight and volume: 21.2kg/ctn, 0.097cbm/ctn
 Estimated Total weight and volume : *
 Incoterms of your quote: FOB
 Lead time: 25~35days



LEDTRONICS-STM-S014-450W-HLV [1000W PHILIPS METAL HALIDE REPLACEMENT



In.Voltage	Order>50
90-277V AC 5Y	\$140.65
480V AC 5Y	\$168.65
90-277V AC 7Y	\$170.19
480V AC 7Y	\$204.19

Remark: certain discount provided based on order qty, sample order add 12%

·POWER: 450W/850W/1000W/1200W/1600W

- Heavy-gauge, die-cast aluminum housing with cooling fins.
- Corrosion resistant electrocoat black finish.
- Continuous silicone gasket surrounds lens for weather - tight seal.
- Adjustable angle mounting brackets included.
- High Output SMD LED's with anti UV lens optics.
- High power factor, low THD driver with 6kV/4kA surge protection.
- Optional 20kV/10kA surge protector available.

450watt area light (with big yoke / slipfilter)

IP66, 0-10V, **140~160lm/watt**, Black HOUSING ,
 Beam angle: 10° ,25° 45° , 60° ,120*90°
 UL ETL driver, 90-277V AC, 347V AC, 480V AC
Low THD driver with 6kV surge protection
 Install fitting : slipfilter / big yoke
Optional 20KV/10KA surge protector(option)

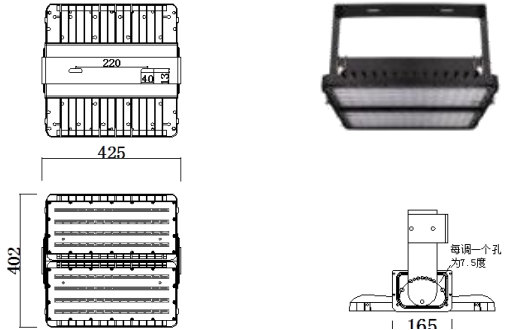

LEDTRONICS-STM-S014-850W-HLV [2000W PHILIPS METAL HALIDE REPLACEMENT



In.Voltage	Order>50
90-277V AC 5Y	\$275.53
480V AC 5Y	\$331.53
90-277V AC 7Y	\$334.61
480V AC 7Y	\$402.61

Remark: certain discount provided based on order qty, sample order add 12%

·POWER: 450W/850W/1000W/1200W/1600W

- Heavy-gauge, die-cast aluminum housing with cooling fins.
- Corrosion resistant electrocoat black finish.
- Continuous silicone gasket surrounds lens for weather - tight seal.
- Adjustable angle mounting brackets included.
- High Output SMD LED's with anti UV lens optics.
- High power factor, low THD driver with 6kV/4kA surge protection.
- Optional 20kV/10kA surge protector available.

850watt area light (with big yoke / slipfilter)

IP66, 0-10V, **140~160lm/watt**, Black HOUSING ,
 Beam angle: 10° ,25° 45° , 60° ,120*90°
 UL ETL driver, 90-277V AC, 347V AC, 480V AC
Low THD driver with 6kV surge protection
 Install fitting : slipfilter / big yoke
Optional 20KV/10KA surge protector(option)

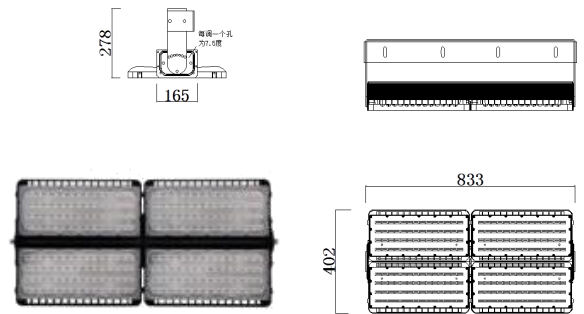

LEDTRONICS-STM-S014-450W-HV

Shipping port: Shenzhen or Guangzhou
 Standard package per item: 1pcs/ctn
 Standard package dimensions: 56cm*91cm*23cm/ctn
 Standard package weight: 22.7kg/ctn
 Estimated weight and volume: 25.2kg/ctn , 0.1172cbm/ctn
 Estimated Total weight and volume : *
 Incoterms of your quote: FOB
 Lead time: 25~35days

LEDTRONICS-STM-S014-850W-HV

Shipping port: Shenzhen or Guangzhou
 Standard package per item: 1pcs/ctn
 Standard package dimensions: 56cm*91cm*23cm/ctn
 Standard package weight: 23.8kg/ctn
 Estimated weight and volume: 25.2kg/ctn , 0.1172cbm/ctn
 Estimated Total weight and volume : *
 Incoterms of your quote: FOB
 Lead time: 25~35days



LEDTRONICS-STM-S015-650W-HLV [1500W PHILIPS METAL HALIDE REPLACEMENT]



In.Voltage	Order>50
90-277V AC 3Y	\$175.15
480V AC 3Y	\$221.54
90-277V AC 5Y	\$234.45
480V AC 5Y	\$291.58

Remark: certain discount provided based on order qty, sample order add 12%

- Heavy-gauge, die-cast aluminum housing with cooling fins.
- Corrosion resistant electrocoat black finish.
- Continuous silicone gasket surrounds lens for weather - tight seal.
- Adjustable angle mounting brackets included.
- High Output SMD LED's with anti UV lens optics.
- High power factor, low THD driver with 6kV/4kA surge protection.
- Optional 20kV/10kA surge protector available.

LEDTRONICS-STM-S015-850W-HLV [2000W PHILIPS METAL HALIDE REPLACEMENT]



In.Voltage	Order>50
90-277V AC 3Y	\$237.40
480V AC 3Y	\$286.07
90-277V AC 5Y	\$316.73
480V AC 5Y	\$376.87

Remark: certain discount provided based on order qty, sample order add 12%

- Heavy-gauge, die-cast aluminum housing with cooling fins.
- Corrosion resistant electrocoat black finish.
- Continuous silicone gasket surrounds lens for weather - tight seal.
- Adjustable angle mounting brackets included.
- High Output SMD LED's with anti UV lens optics.
- High power factor, low THD driver with 6kV/4kA surge protection.
- Optional 20kV/10kA surge protector available.

650watt area light (with big yoke)

IP66, 0-10V, **115-135lm/watt**, Black HOUSING ,
Beam angle: 60
UL ETL driver, 90-277V AC, 347V AC, 480V AC
Low THD driver with 6kV surge protection
Install fitting : big yoke
Optional 20KV/10KA surge protector(option)



850watt area light (with big yoke / slipfilter)

IP66, 0-10V, **115-135lm/watt**, Black HOUSING ,
Beam angle: 60°
UL ETL driver, 90-277V AC, 347V AC, 480V AC
Low THD driver with 6kV surge protection
Install fitting : slipfilter / big yoke
Optional 20KV/10KA surge protector(option)



LEDTRONICS-STM-S015-650W-HLV

Shipping port: Shenzhen or Guangzhou
Standard package per item: 1pcs/ctn
Standard package dimensions: 50cm*50cm*50cm/ctn
Standard package weight: 15.6kg/ctn
Estimated weight and volume:16.8kg/ctn , 0.125cbm/ctn
Estimated Total weight and volume : *
Incoterms of your quote: FOB
Lead time: 25~35days

LEDTRONICS-STM-S015-850W-HLV

Shipping port: Shenzhen or Guangzhou
Standard package per item: 1pcs/ctn
Standard package dimensions: 58cm*58cm*51cm/ctn
Standard package weight: 17.8kg/ctn
Estimated weight and volume:18.6kg/ctn , 0.17cbm/ctn
Estimated Total weight and volume : *
Incoterms of your quote: FOB
Lead time: 25~35days



LEDTRONICS-STM-S016-650W-HLV [1500W PHILIPS METAL HALIDE REPLACEMENT]



In.Voltage	Order>50
90-277V AC 5Y	\$257.01
480V AC 5Y	\$296.99
90-277V AC 7Y	\$326.66
480V AC 7Y	\$375.21

Remark: certain discount provided based on order qty, sample order add 12%

650watt area light (with big yoke / slipfilter)

IP66, 0-10V, **120~140lm/watt**, Black HOUSING ,
 Beam angle: 25° ,60° ,90°
 UL ETL driver, 90-277V AC, 347V AC, 480V AC
Low THD driver with 6kV surge protection
 Install fitting : slipfilter / big yoke
Optional 20KV/10KA surge protector(option)

- Heavy-gauge, die-cast aluminum housing with cooling fins.
- Corrosion resistant electrocoat black finish.
- Continuous silicone gasket surrounds lens for weather - tight seal.
- Adjustable angle mounting brackets included.
- High Output SMD LED's with anti UV lens optics.
- High power factor, low THD driver with 6kV/4kA surge protection.
- Optional 20kV/10kA surge protector available.

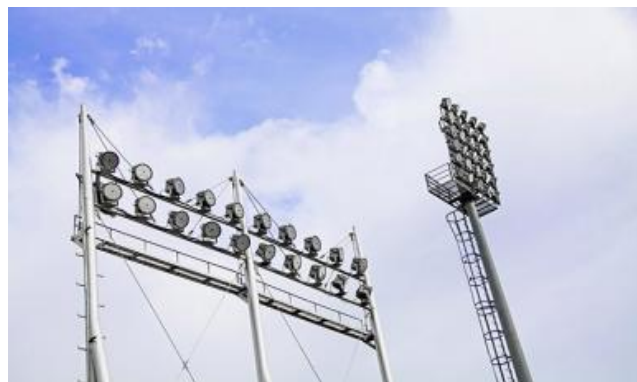

LEDTRONICS-STM-S016-850W-HLV [2000W PHILIPS METAL HALIDE REPLACEMENT]



In.Voltage	Order>50
90-277V AC 5Y	\$382.68
480V AC 5Y	\$422.66
90-277V AC 7Y	\$478.34
480V AC 7Y	\$526.89

Remark: certain discount provided based on order qty, sample order add 12%

850watt area light (with big yoke / slipfilter)

IP66, 0-10V, **120~140lm/watt**, Black HOUSING ,
 Beam angle: 45° ,60°
 UL ETL driver, 90-277V AC, 347V AC, 480V AC
Low THD driver with 6kV surge protection
 Install fitting : slipfilter / big yoke
Optional 20KV/10KA surge protector(option)

- Heavy-gauge, die-cast aluminum housing with cooling fins.
- Corrosion resistant electrocoat black finish.
- Continuous silicone gasket surrounds lens for weather - tight seal.
- Adjustable angle mounting brackets included.
- High Output SMD LED's with anti UV lens optics.
- High power factor, low THD driver with 6kV/4kA surge protection.
- Optional 20kV/10kA surge protector available.



LEDTRONICS-STM-S016-650W-HLV

Shipping port: Shenzhen or Guangzhou
 Standard package per item: 1pcs/ctn
 Standard package dimensions: 53cm*53cm*58cm/ctn
 Standard package weight: 18.6kg/ctn
 Estimated weight and volume: 21kg/ctn , 0.138cbm/ctn
 Estimated Total weight and volume : *
 Incoterms of your quote: FOB
 Lead time: 25~35days

LEDTRONICS-STM-S016-850W-HLV

Shipping port: Shenzhen or Guangzhou
 Standard package per item: 1pcs/ctn
 Standard package dimensions: 58cm*58cm*67cm/ctn
 Standard package weight: 22.8kg/ctn
 Estimated weight and volume: 24.6kg/ctn , 0.105cbm/ctn
 Estimated Total weight and volume : *
 Incoterms of your quote: FOB
 Lead time: 25~35days



LEDTRONICS-STM-S017-650W-HLV [1500W PHILIPS METAL HALIDE REPLACEMENT]

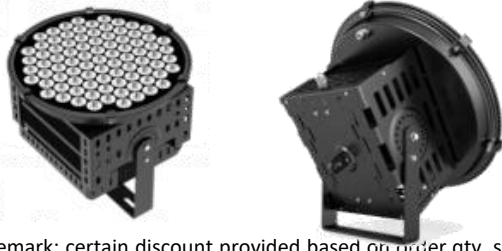

In.Voltage	Order>50
90-277V AC 5Y	\$355.20
480V AC 5Y	\$395.18
90-277V AC 7Y	\$431.70
480V AC 7Y	\$480.25

Remark: certain discount provided based on order qty, sample order add 12%

- Heavy-gauge, die-cast aluminum housing with cooling fins.
- Corrosion resistant electrocoat black finish.
- Continuous silicone gasket surrounds lens for weather - tight seal.
- Adjustable angle mounting brackets included.
- High Output SMD LED's with anti UV lens optics.
- High power factor, low THD driver with 6kV/4kA surge protection.
- Optional 20kV/10kA surge protector available.

650watt area light (with big yoke / slipfilter)
 IP66, 0-10V, **120~140lm/watt**, Black HOUSING ,
 Beam angle: 10° ,15° ,30° ,60°
 UL ETL driver, 90-277V AC, 347V AC, 480V AC
Low THD driver with 6kV surge protection
 Install fitting : slipfilter / big yoke
Optional 20KV/10KA surge protector(option)

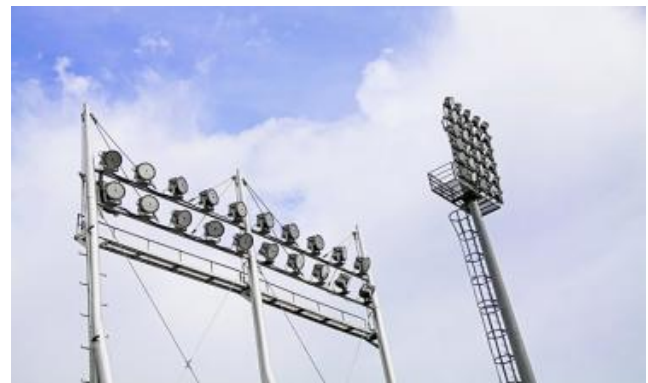

LEDTRONICS-STM-S017-850W-HLV [2000W PHILIPS METAL HALIDE REPLACEMENT]

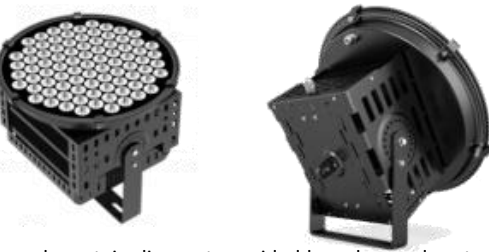

In.Voltage	Order>50
90-277V AC 5Y	\$437.23
480V AC 5Y	\$477.21
90-277V AC 7Y	\$536.70
480V AC 7Y	\$585.25

Remark: certain discount provided based on order qty, sample order add 12%

- Heavy-gauge, die-cast aluminum housing with cooling fins.
- Corrosion resistant electrocoat black finish.
- Continuous silicone gasket surrounds lens for weather - tight seal.
- Adjustable angle mounting brackets included.
- High Output SMD LED's with anti UV lens optics.
- High power factor, low THD driver with 6kV/4kA surge protection.
- Optional 20kV/10kA surge protector available.

850watt area light (with big yoke / slipfilter)
 IP66, 0-10V, **120~140lm/watt**, Black HOUSING ,
 Beam angle: 10° ,15° ,30° ,60°
 UL ETL driver, 90-277V AC, 347V AC, 480V AC
Low THD driver with 6kV surge protection
 Install fitting : slipfilter / big yoke
Optional 20KV/10KA surge protector(option)



LEDTRONICS-STM-S017-650W-HLV

Shipping port: Shenzhen or Guangzhou
 Standard package per item: 1pcs/ctn
 Standard package dimensions: 58cm*58cm*41cm/ctn
 Standard package weight: 19.6kg/ctn
 Estimated weight and volume: 21.2kg/ctn , 0.138cbm/ctn
 Estimated Total weight and volume : *
 Incoterms of your quote: FOB
 Lead time: 25~35days

LEDTRONICS-STM-S017-850W-HLV

Shipping port: Shenzhen or Guangzhou
 Standard package per item: 1pcs/ctn
 Standard package dimensions: 58cm*58cm*47cm/ctn
 Standard package weight: 23.8kg/ctn
 Estimated weight and volume: 25.2kg/ctn , 0.105cbm/ctn
 Estimated Total weight and volume : *
 Incoterms of your quote: FOB
 Lead time: 25~35days

